



Owner's Manual AIR MOVER



INSTRUCTION MANUAL

SAVE THESE INSTRUCTIONS FOR FUTURE REFERENCE

READ AND UNDERSTAND ALL WARNINGS AND INSTRUCTIONS BEFORE USING THIS AIR MOVER!



WARNING! To reduce the risk of fire, electric shock, or injury:

- 1)** Read the manual carefully and completely before attempting to operate the unit. This manual has important information for the use and safe operation of the machine. Following the recommendations outlined in this manual will assure years of satisfactory service from your unit.
- 2)** Improper connection of the equipment grounding conductor can result in a risk of fire, electrical shock or personal injury. Always use a three-wire electrical system connected to the electrical ground. For maximum protection against electrical shock, use a circuit that is protected by a ground fault circuit interrupter. Check with a qualified electrician or service person if you are in doubt as to whether your outlet is properly grounded. Do not use a unit with a damaged cord or plug.
- 3)** Machines can cause an explosion when near flammable materials and vapors. Do not use or store this machine with or near fuels, grain dust, solvents, thinners, or other flammable materials. Do not use flammables to clean this machine.
- 4)** Do not immerse or use this unit in standing water. Such use may cause electrical shock. To avoid electrical shock, do not expose the unit to rain – store it indoors only. Do not expose the unit to freezing temperatures.
- 5)** Do not move or carry the unit when it is turned on. Do not pull or carry by the cord, use cord as a handle, close a door on the cord or pull cord around sharp edges or corners. Keep cord away from heated surfaces. Do not unplug cord by pulling on it. To unplug, grasp plug, not the cord. Do not handle plug or air mover with wet hands.
- 6)** Do not put any objects into openings. Do not use with any opening blocked; keep free of dust, lint, hair and anything that may reduce air flow. Keep hair, loose clothing, fingers and all parts of the body away from openings and moving parts.
- 7)** Turn off all controls before unplugging.
- 8)** Operate unit on a level and stable surface to prevent it from falling and possible cause of injury or damage.
- 9)** Do not drop or throw the unit. Treatment of this type can cause damage to the components and create hazardous conditions.

OPERATION:

Plug your air mover into a standard grounded outlet with the correct voltage and amperage. If you are unsure about the outlet, contact your supervisor. Turn on the switch and check that the unit operates properly before letting it run.

MAINTENANCE:

- Inspect the electrical cord and wiring for damage or discoloration
- Inspect for loose fasteners
- Clean screens on the side and front of the unit
- Listen for abnormal sounds
- Keep unit clean

PERIODIC MAINTENANCE:

Use compressed air or a vacuum to remove lint and other debris from the motor, screen and blower wheel. Do not use a pressure washer to clean the unit.

SPECIFICATIONS	
VOLTS	240V
POWER	1/4HP
CYCLE	50Hz
MAX AIR VOLUME	1100CFM
AMPS LOW/MID/HIGH SPEEDS	1.6/1.7AMPS
WEIGHT	9.5KGS
SIZE L/W/H	55x43.5x23cm
SPEED	2 SPEEDS
CORD LENGTH	5M

GROUNDING INSTRUCTIONS:

This machine must be grounded. If it should malfunction or break down, grounding provides a path of least resistance for electric current to reduce the risk of electric shock. This machine is equipped with a cord having an equipment-grounding conductor and grounding plug. The plug must be inserted into an appropriate outlet that is properly installed and grounded in accordance with all local codes and ordinances.

TROUBLESHOOTING:

Problem	Cause	Solution
Unit will not run.	<ol style="list-style-type: none">1. No power to unit.2. Switch not on.3. Switch is faulty.4. Faulty/broken cord or motor wire	<ol style="list-style-type: none">1. Plug unit in. Check circuit breaker.2. Place in "ON" position.3. Replace switch.4. Perform continuity check, using volt/amp meter. Repair/replace faulty broken wire.
Unit runs but air mover makes loud scraping noise.	<ol style="list-style-type: none">1. Unit has been severely jolted causing blower wheel to rub against housing.2. Unit has been severely jolted causing housing to deform.	<ol style="list-style-type: none">1. Remove motor and replace damaged motor mounts.2. Replace blower wheel.
Unit runs but vibrates excessively.	<ol style="list-style-type: none">1. Severe jolt has bent motor shaft causing unit to be out of balance.2. Air mover blade damaged.3. Dirt build up on one side of air mover blade.	<ol style="list-style-type: none">1. Remove and replace motor.2. Replace blade if necessary.3. Clean air mover blade.
Unit runs but blower wheel does not turn.	<ol style="list-style-type: none">1. Motor bearings are failing or motor has developed an internal electrical fault.2. Intake grill and/or exhaust grill is obstructed.3. Excessive duct length.	<ol style="list-style-type: none">1. Replace motor.2. Remove obstruction.3. Reduce duct length to recommended maximum

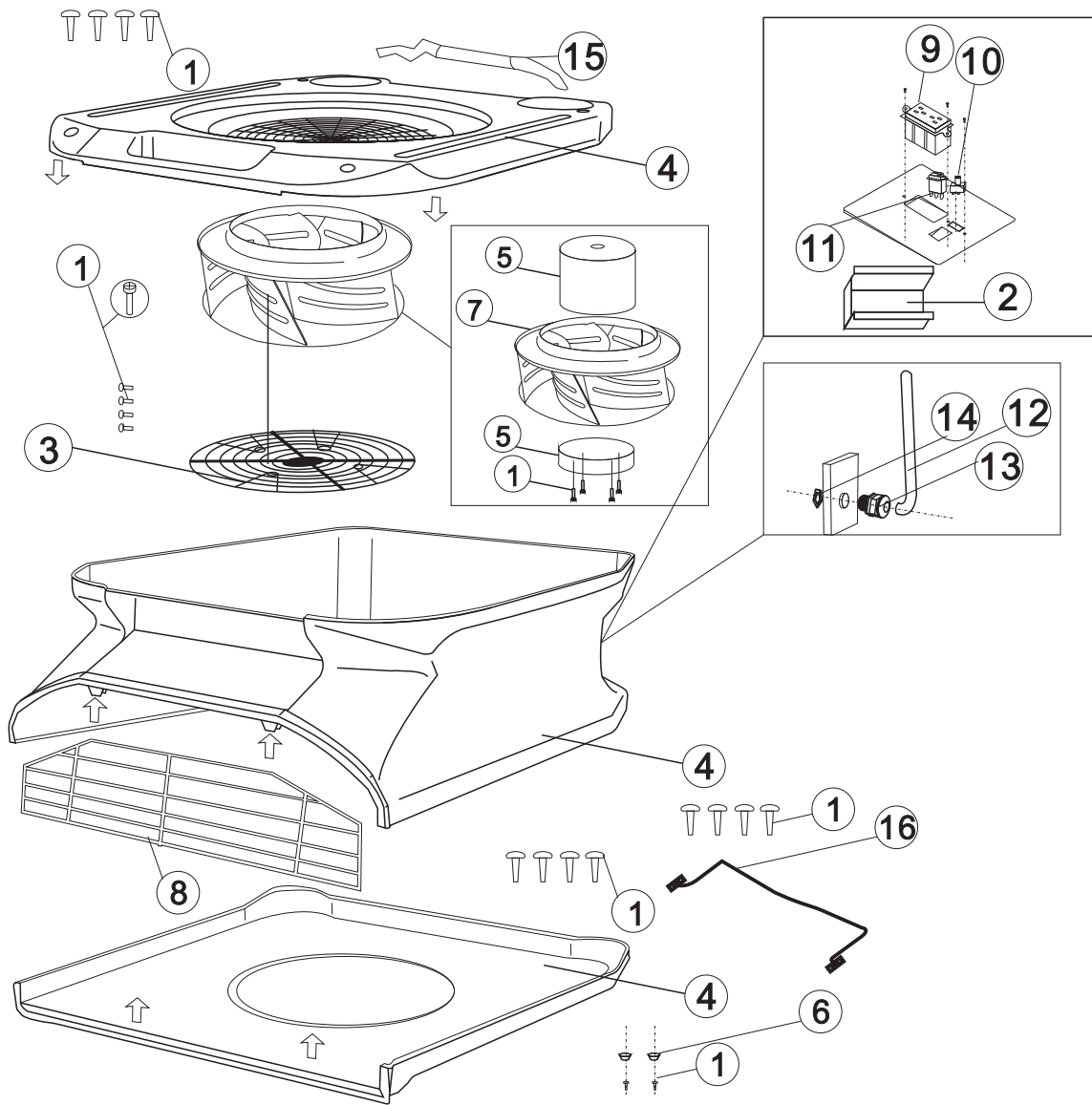

ref#	description	qty	ref#	description	qty
1	screw	25	9	gfcı outlet,female plug	1
2	electric control box	1	10	circuit breaker	1
3	wire grill	1	11	on/off rocker switch,blk	1
4	Housing	3	12	power cord	1
5	AC motor	1	13	strain relief-lq tight	1
6	rubber foot	4	14	nut,hex	1
7	fan blade	1	15	Handle	1
8	outlet grin	1	16	kickstand	1