



MECY 14, 18 & 25 EVAPORATIVE COOLER



USER MANUAL

SAVE THESE INSTRUCTIONS FOR FUTURE REFERENCE

PREFACE

We sincerely appreciate your trust and support in our product.

To ensure properly and effectively use,
please read through this manual before using this product.

SAFETY PRECAUTIONS

! Please unplug the power connection before cleaning and maintaining



1 Please go through the manual thoroughly before operating the water cooling fan.



2 Do not open the control panel or the cover of the inverter without qualified guidance.



3 Do not operate the control panel, or touch the power plug and the cover of the inverter with wet hands.



4 Do not share the plug with other equipment because of the fan's high start-up current. Please choose an over 2.0 MM (14 AWG) extension cord set for the water cooling fan. Also, the extension cord should not be over 25 m. Connect the fan with an irregular cord set could cause short-circuit.



5 Avoid using old extension cords or sockets. Keep the wires away from heat and fire. Do not place the wires on where man or traffic crossing to prevent wire being stepped or pulled which may cause accident.



6 Do not remove the earth part of the plug. Choose a right and tight socket, do not use one without earthing. For your safety, do not change the power cord or the wiring of the control panel.

! Please unplug the power connection before cleaning and maintaining



7 This unit is not capable of and should never be used to draw: (1) flammable gases, including oil gas, fuel gas, pure oxygen, hydrogen gas, etc. (2) flammable liquid, such as gas, toluene, etc. (3) dust or crystal of under 80°C fire point, including magnesium, platinum, gun powder, etc.



8 If the fan does not function well, please turn off the power and check the wire, socket, and extension cord. After checking, restart the fan after a while. If the problem is not solved, please contact where you purchase the fan or contact us to arrange repair service. Do not detach or change spare parts on your own.



9 Please place the water cooling fan on a flat ground and step on the brake button while operating. When encounter a flood damage, please unplug the fan and move it to somewhere safe.



10 When not using the cooling fan for a while, please open the drain at the bottom or turn on the auto drain to let out the water. Then turn on the fan for 1-2 hour to dry the cooling pad. After drying, unplug the fan for storage.



11 To fill the tank manually, please turn off the fan and open the ice cube entrance to fill the water. Make sure the power is away from water to prevent accident.



12 Do not face the air inlet side (the cooling pad side) to any burning or smoking object, including matches, ash, cigarette, cigar, charcoal, etc. Damages or accidents caused by the preceding issue are not cover by the warranty.



13

While operating, do not open the cover of the inverter, the cover guard of the fan, or the cooling pad on the back; also, do not through anything to the fan to avoid accident.



14

The water cooling fans are heavy. Please be careful while moving the cooling fan, or it may cause man-injuries if bumping or overturning occurs.



15

Do not open the ice cube entrance while the fan is operating. Approaching the running fan blades would cause injuries, and could crack the blades.



16

While cleaning the cooling fan, do not spray water to the control panel or the cover of inverter to avoid damage.



17

Do not convert, disassemble, or repair the product without instruction. Damage caused by the preceding issue are not cover by the warranty. Please contact us for support.



18

Please do not convert or change the fan blades on your own to avoid accident.



19

Do not move the water cooling fan by pulling the attaching hose. This could cause fan damage.

PERFORMANCE AND SPECIFICATION

Product Performance



Adjust the fan speed freely with the power saving stepless inverter control system.



Move freely with the castor rack.



Evaporative cooling system. Cool with no mist.



You can add some ice to enhance the cooling effect.



Large water storage to support 4-6 hour operation.



Low water storage detective device to avoid the pump from burning out.



Filters dust while cooling the air,
and produce fresher air.



Portable design,
take it everywhere you want.



100% made in Taiwan
with high quality.



Strength and well-designed
PE frame structure.



Save electricity in an air conditioned space
and cool the room faster.

MECY 48

Specification

Model	MECY 48	Rotating Speed (Max.)	660 RPM	Wind Fetch (Max.)	30m up
External Frame	PE	Sound Volume (Max.)	75dB	Size	L180*W88*H220cm
Blades	50" 3 SMC Fiberglass Blades	Voltage (Regular)	1 § 230V, 50Hz	Water Storage	230L
Motor	2HP F Grade	Current (Max.)	7.2A	Weight	185kg
Pole	10P	Power Consumption (Max.)	1100 w/hr	Total Weight with Water	390kg

(The sound volume data is detected from 3 m near, and will be verified in different surrounding area.)

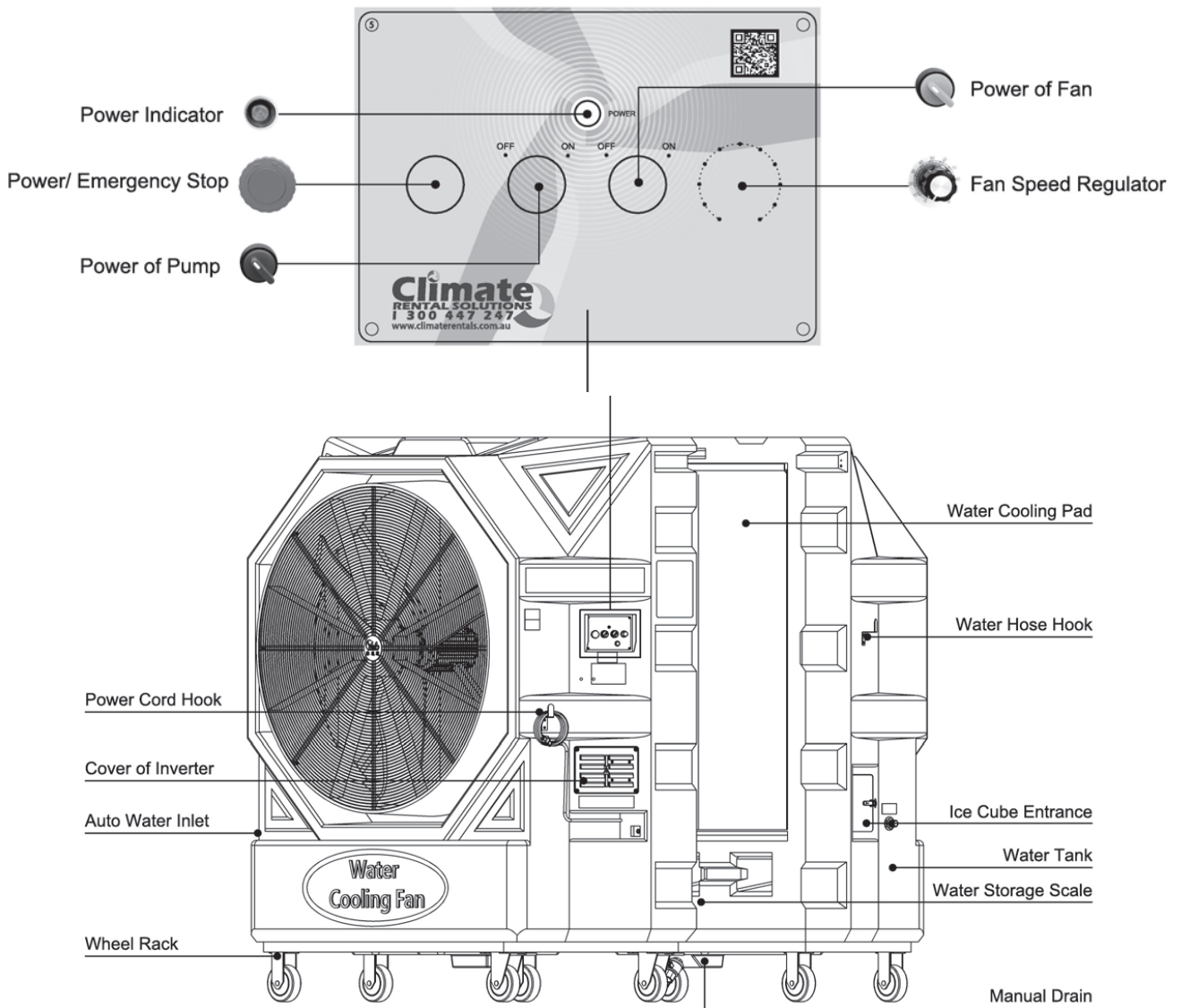

MECY 32

Specification

Model	MECY 32	Rotating Speed (Max.)	550 RPM	Wind Fetch (Max.)	25m up
External Frame	PE	Sound Volume (Max.)	70dB	Size	L155*W81*H186cm
Blades	42" 6 Nylon 6 + Fiber Blades	Voltage (Regular)	1 ϕ 230V, 50Hz	Water Storage	180L
Motor	1.5HP F Grade	Current (Max.)	6.2A	Weight	120kg
Pole	10P	Power Consumption (Max.)	960 w/hr	Total Weight with Water	300kg

(The sound volume data is detected from 3 m near, and will be verified in different surrounding area.)

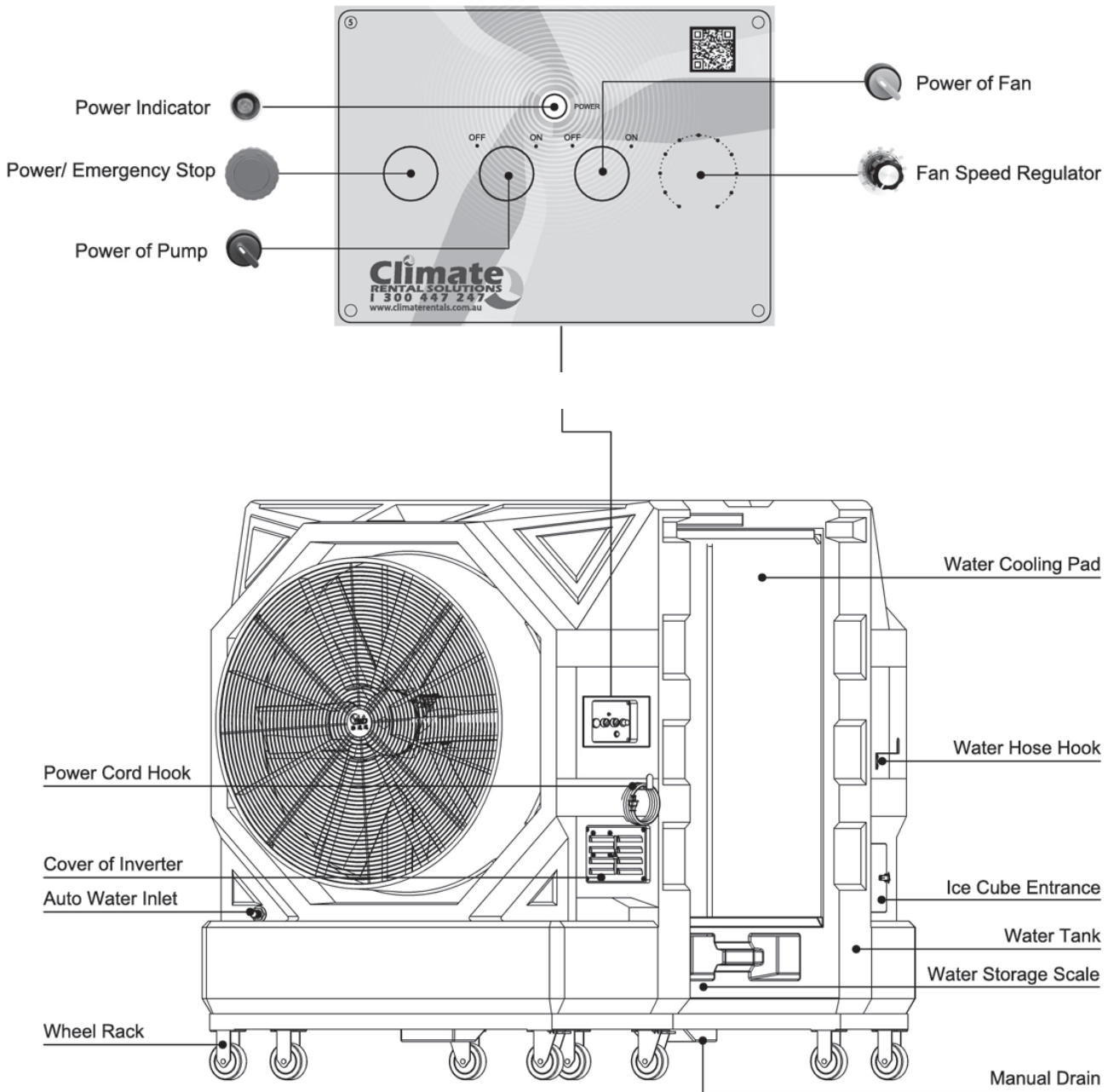

MECY 22

Specification

Model	MECY 22	Rotating Speed (Max.)	1000RPM	Wind Fetch (Max.)	20m up
External Frame	PE	Sound Volume (Max.)	65dB	Size	L126*W72*H160cm
Blades	30" 3 Nylon 6 + Fiber Blades	Voltage (Regular)	1 ϕ 230V, 50Hz	Water Storage	145L
Motor	1/2HP F Grade	Current (Max.)	5.1A	Weight	90kg
Pole	6P	Power Consumption (Max.)	750 w/hr	Total Weight with Water	235kg

(The sound volume data is detected from 3 m near, and will be verified in different surrounding area.)

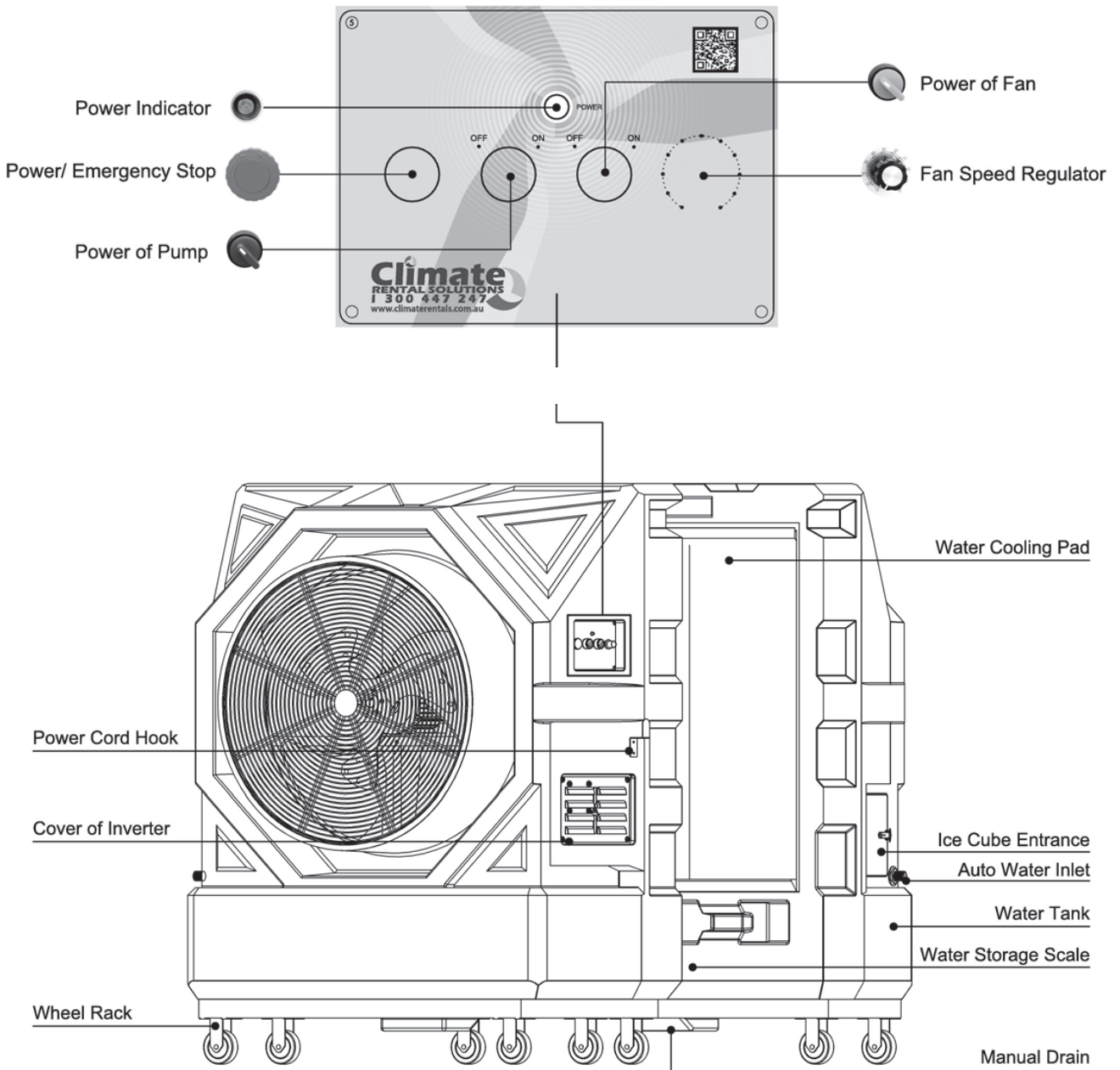

MECY 25

Specification

Model	MECY 25	Rotating Speed (Max.)	1100 RPM	Wind Fetch (Max.)	20m up
External Frame	PE	Sound Volume (Max.)	60dB	Size	L132*W69*H172cm
Blades	30° 3 Nylon 6 + Fiber Blades	Voltage (Regular)	1 ϕ 230V, 50Hz	Water Storage	170L
Motor	1/2HP F Grade	Current (Max.)	6.1A	Weight	100kg
Pole	6P	Power Consumption (Max.)	900 w/hr	Total Weight with Water	270kg

(The sound volume data is detected from 3 m near, and will be verified in different surrounding area.)

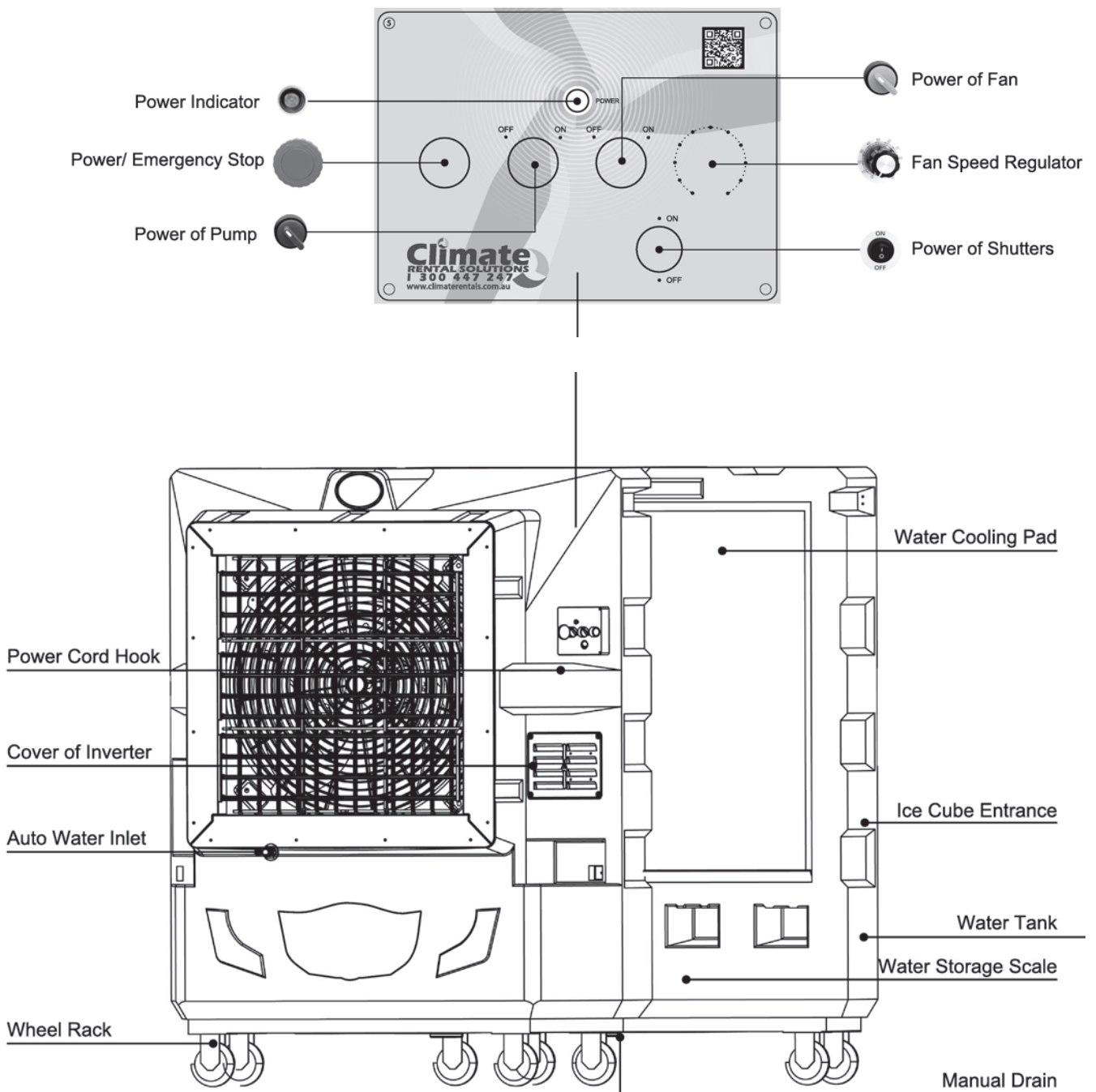

MECY 18

Specification

Model	MECY 18	Rotating Speed (Max.)	1100 RPM	Wind Fetch (Max.)	15m up
External Frame	PE	Sound Volume (Max.)	55dB	Size	L98*W70*H141cm
Blades	24" 3 Nylon 6 + Fiber Blades	Voltage (Regular)	1 ϕ 230V, 50Hz	Water Storage	120L
Motor	1/2HP F Grade	Current (Max.)	5.2A	Weight	75kg
Pole	6P	Power Consumption (Max.)	720 w/hr	Total Weight with Water	195kg

(The sound volume data is detected from 3 m near, and will be verified in different surrounding area.)

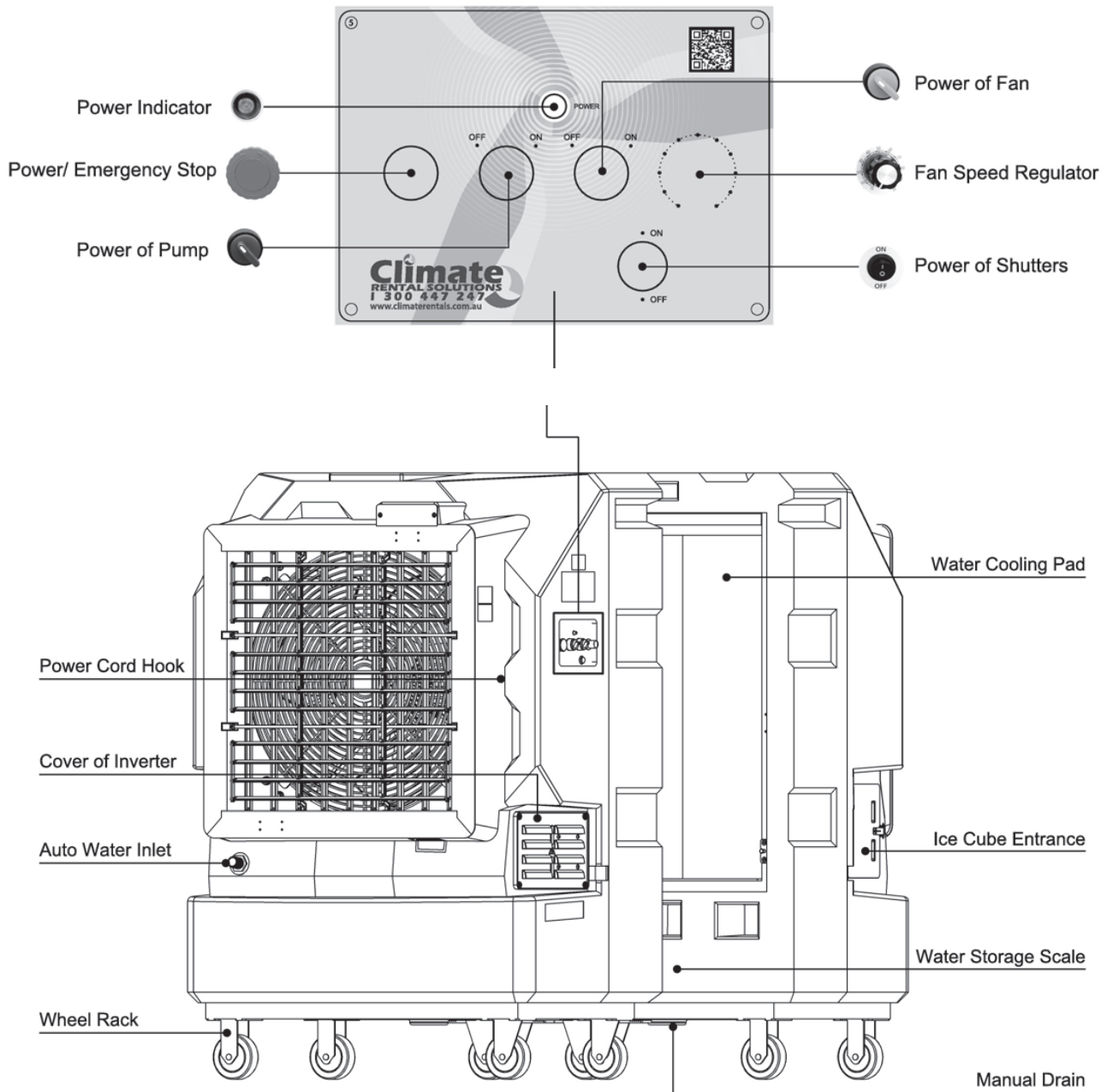

MECY 14

Specification

Model	MECY 14	Rotating Speed (Max.)	1380 RPM	Wind Fetch (Max.)	15m up
External Frame	PE	Sound Volume (Max.)	55dB	Size	L75*W50*H130cm
Blades	18° 3 Nylon 6 + Fiber Blades	Voltage (Regular)	1 § 230V, 50Hz	Water Storage	60L
Motor	1/3HP F Grade	Current (Max.)	3.2A	Weight	45kg
Pole	4P	Power Consumption (Max.)	410 w/hr	Total Weight with Water	105kg

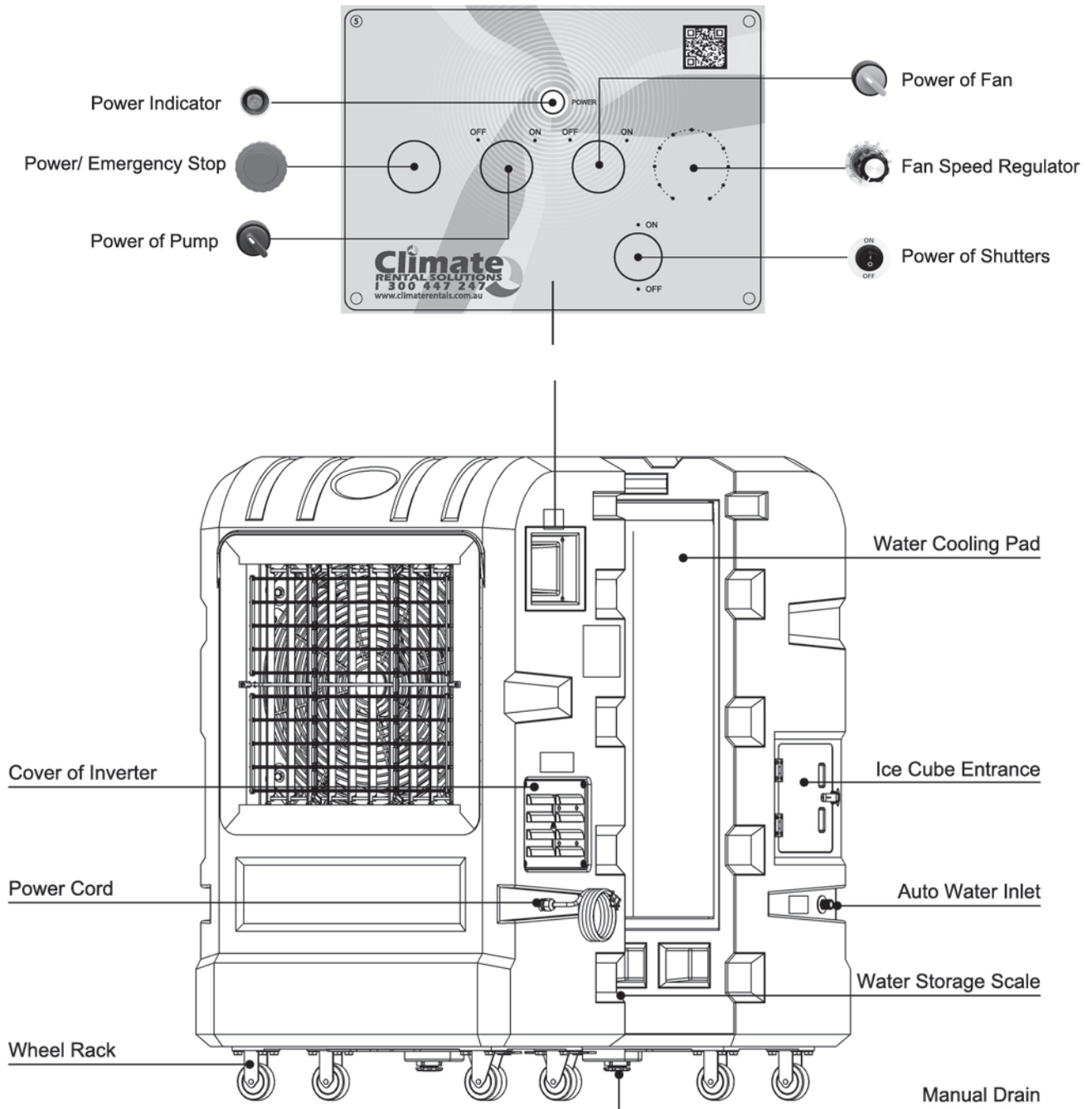

(The sound volume data is detected from 3 m near, and will be verified in different surrounding area.)



INSTRUCTION

Operating Instruction

1 Please follow the conditions below:

- A  Please connect the product with AC 110V or AC 220V, 50/60 Hz, Single Phase power source. (There is a voltage instruction sticker on the product.)
- B  The power voltage should not be 10% higher or lower than the indicated voltage.
- C  Suitable Operating Temperature: 0°C~45°C. Do not place the machine near heat or fire.

2 When water storage level comes low, the pump would automatically stop. Please fill the tank to the maximum of the scale and do not over fill.

3 Do not stand, sit, or place thing on the fan. It may cause damage, overturning, or injury when things drop.

4 Keep the buckle of the ice cube entrance fasten after use.

5 Do not detach the cover guard and other parts of the fan, or it may cause fan damage or accident.

6 Please provide an isolated socket or cable for the fan. Do not share the power source with other high power consumption equipment to ensure safety.

7 By turn off the pump switch, you can use this product with only the fan function.

8 To ensure the best cooling effect, we suggest to wash the cooling pad and change the tank water once every week. Open the manual drain at the bottom, then fill the tank again after the following cleaning process can last the pump's service life longer.

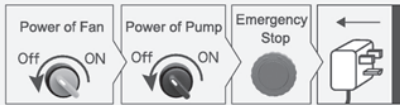

A. Attention! Before the cleaning process, please switch off the fan, plug out, and move the fan away from power source and other equipment.



B. Open the manual drain below, and wash the cooling pad with soft brush from the top. After washing, wait until the waste water drain away, then close the drain.



C. When washing the cooling pad, do not spray water directly to the control panel or the cover of the inverter. This will damage the motor controller.



D. Wipe the fan external frame with wet towel, do not spray water or wipe it with volatile liquid.

9 Product damages cause by the following issues are not cover by our warranty.

- A. Power connect with incorrect voltage.
- B. Damage in handling or in transit caused by users.
- C. Damage caused by natural calamities.
- D. Structural damage caused by volatile liquid or gas.
- E. Accident or damage caused by wire connection or power sharing with other equipment.

- F. Damage caused by converting or changing of the parts.
- G. Malfunction caused by wire altering.
- H. Damage caused by water spray or rain.
- I. Pump damage caused by clogging due to careless of cleaning.



Please contact us for any questions.

Feature and Manual



Stepless Fan Speed Control

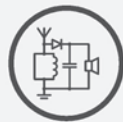

Short-Circuit Protection



Soft Start Motor



Low Water Level Protection



Over-Current Protection

Feature and Manual



1 Operation Process and Auto Water Inlet:

Attach the quick connector of the water inlet hose to a faucet, and tighten it. Check and make sure the other end of the connector is fastened to the cooling fan. Open the faucet and fill the water tank to the highest level of the water storage scale. Turn on the power of pump (see Control Panel Instruction below), and let the water wet the cooling pad for 1-2 minutes, then turn on the power of fan and adjust the fan speed. By following the process, you will get the best cooling effect of your fan.

2 Control Panel Instruction:

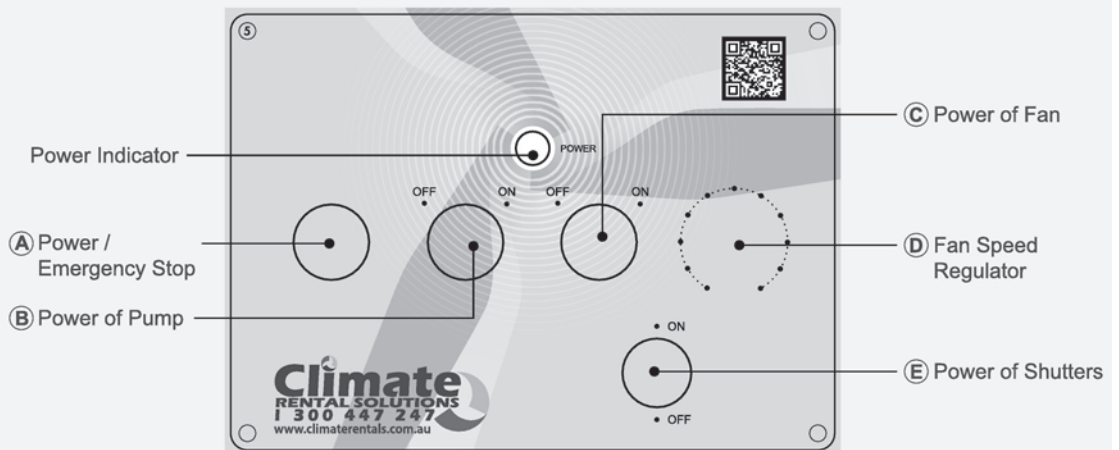

A		Power / Emergency Stop	<ul style="list-style-type: none"> Twist the button and light up the power indicator. Press the button to turn off the power when any emergency occur. Please follow the on and off process below for usual usage. Attention: Once you press the Emergency Stop, restart the fan after 20 second.
B		Power of Pump	<ul style="list-style-type: none"> Switch on the button, the pump will start as there is sufficient water inside the tank. The pump would not start when the water level is low. Please fill the tank before use.
C		Power of Fan	<ul style="list-style-type: none"> Switch on the power of fan and turn the fan speed regulator to control the speed.
D		Fan Speed Regulator	<ul style="list-style-type: none"> Control the fan speed as the power of fan is on. From 0-100; the higher the number, the faster the fan.
E		Power of Shutters	<ul style="list-style-type: none"> Control the electric shutters of MECY 14, MECY 18, and MECY 25.

Turn On & Turn Off:

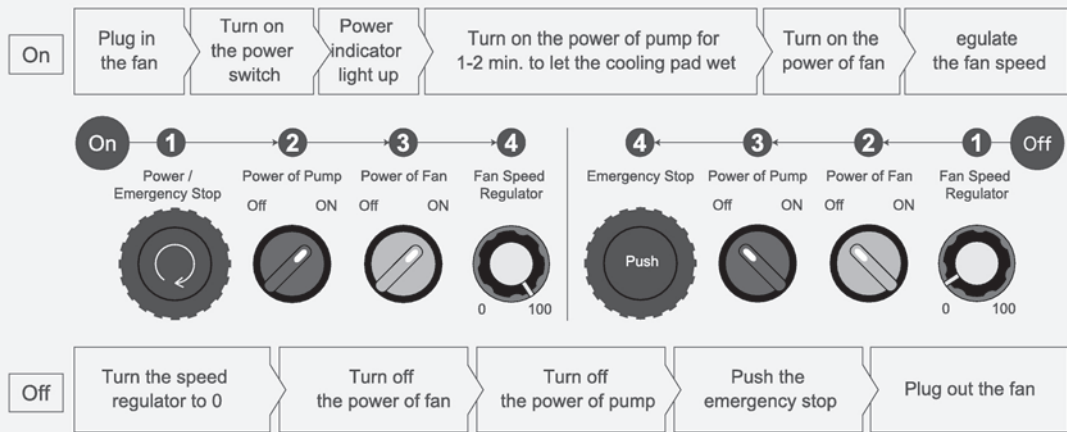

Feature and Manual



Instructions

1\$AC230V

• Power Specification

! WARNING / DANGEROUS

⚡ ELECTRIC SHOCK OPERATE CAREFULLY **⬇️ DON'T SPRAY WATER**

• Inverter and controller of the fan is installed here. Wipe the fan with wet towel. Spraying water could caused electric leakage or short circuit.

 **AVOID HIGH WATER PRESSURE**

WATER IN

- Water inlet pressure should not over 70 PSI.

**AUTOMATIC
OUTFALL**

- Open the auto water drain and turn on the power of pump to drain the water out by the pump. MECY 18 and MECY 14 does not have this function.

WATER OUT



- Manual drain. Open when changing and washing.

 **WARNING**

 **RISK OF
DRAW IN**

 **DANGEROUS
DON'T TOUCH**

- Do not approach or touch the fan while operating.

CLEAN AND MAINTAIN



Change the Water Regularly

- ❶ During use, the dust and particles would deposit inside the tank. This may lower the cooling capacity of the fan and brings bad odor. We suggest to change the water in the tank at least once a week; add more times if needed. And do not spray water directly to the inverter or control panel.
- ❷ The cooling fan can filter dust and particles. When using the fan in an area with bad air, we suggest to open the manual drain or auto drain to let out the water after use. Fill the tank next time when needed.
- ❸ Manual Drain: At the bottom of the cooling fan. Twist the knob to open and let out the water. Twist it back afterward.

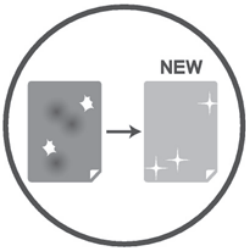

The water cooling pads are consumables. Please contact us or our distributor for replacement when stained or torn.



Warning:

- ❶ Please follow the guide in this manual accurately. Damages and injuries caused by improper use are not cover by the warranty.
- ❷ We are not responsible for accident caused by product converting by users.
- ❸ When notice any problem which may cause during the delivery, please contact us or our distributor in your country for urgent assistance.
- ❹ To avoid any accident or damage, please follow the rules below:
 - You must learn how to operate the machine correctly before use.
 - You must read through the manual and have the knowledge of all the instructions before use.
 - You must read through the manual and understand the label instruction sign before use.

The content of this manual, including the specifications and the design of the products may subject to be modified without prior notice. This manual is protected by copy laws. All rights are reserved by Climate Rental Solutions .