



WWC-1200 WATER CHILLER



OWNER'S MANUAL

SAVE THESE INSTRUCTIONS FOR FUTURE REFERENCE

INDEX

Caution before using	3
Product features (WWC-1200)	5
Caution while maneuvering	6
Instruction for installation	7
Controller manual	8
Instruction & caution for running	10
Maintenance	11
Self-diagnostic code	12
Circuit diagram	13
Model specification	14

CAUTION BEFORE USING



Caution

Make sure to follow these safety tips to use the machine properly and prevent any accident.

- Check the power source's voltage.
(to prevent fire, electric shock)

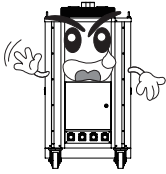

- Use the proper power cord for the machine.

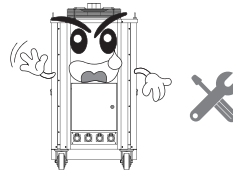

- Do not place and use any flammable material near the machine.
(to prevent fire, damage to the machine)

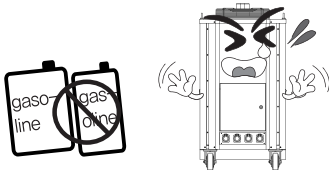

- Do not spray and wipe water, benzene, thinner alcohol directly to the machine
(to prevent fire, electric shock, damage to the machine)

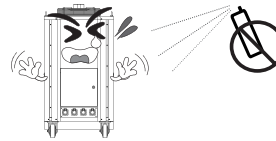

- Do not force the power cord to bent or have it pressed by heavy stuffs.
(to prevent fire, electric shock)

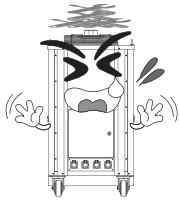

- Do not install the machine near the stuffs easy to burn like curtain, blanket, clothes.
(to prevent fire)

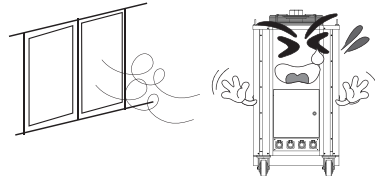

- Do not block the air inlet & outlet port.

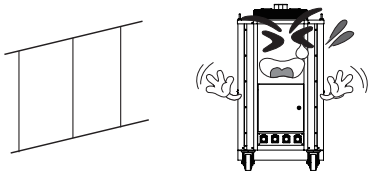

- Do not get the eyes near the air outlet port while running to prevent the burnt from the heat.

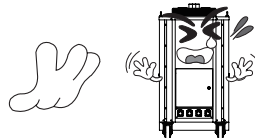



Caution

Make sure to follow these safety tips to use the machine properly and prevent any accident.

- Do not let external substance go into the air inlet & outlet port. (to prevent malfunction)

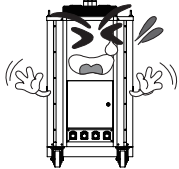

- Make sure to use a proper relay to the machine. (to prevent fire, electric shock)

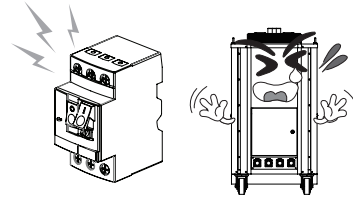

- When not using for a long time, drain out the remaining water inside the machine using drainage valve and place the machine avoiding hot and humid place. (to prevent freeze of the inner component)

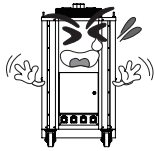

- Make sure to manage the water always clean.

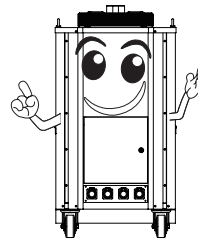

- Do not use or touch the damaged power cord. (to prevent fire, electric shock)

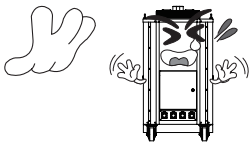

- Make sure to have the power source is connected only with this machine. (to prevent fire, electric shock)

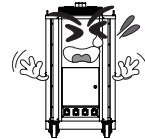

- Do not use or touch the damaged power cord. (to prevent fire, electric shock)

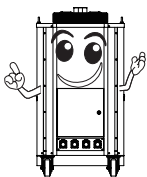

- Make sure to do the grounding of the machine. (to prevent fire, electric shock)

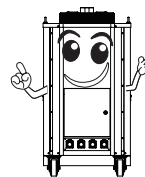

- Do not open the covers while running. (to prevent fire, electric shock)

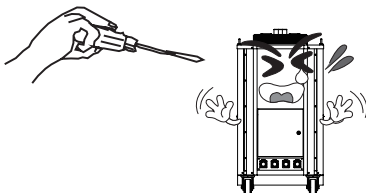

- Never disassemble, repair, modify the machine by your own. (to prevent fire, electric shock. Contact the service center for the maintenance)

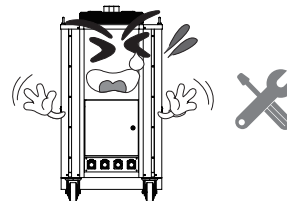

PRODUCT FEATURES (WWC-1200)

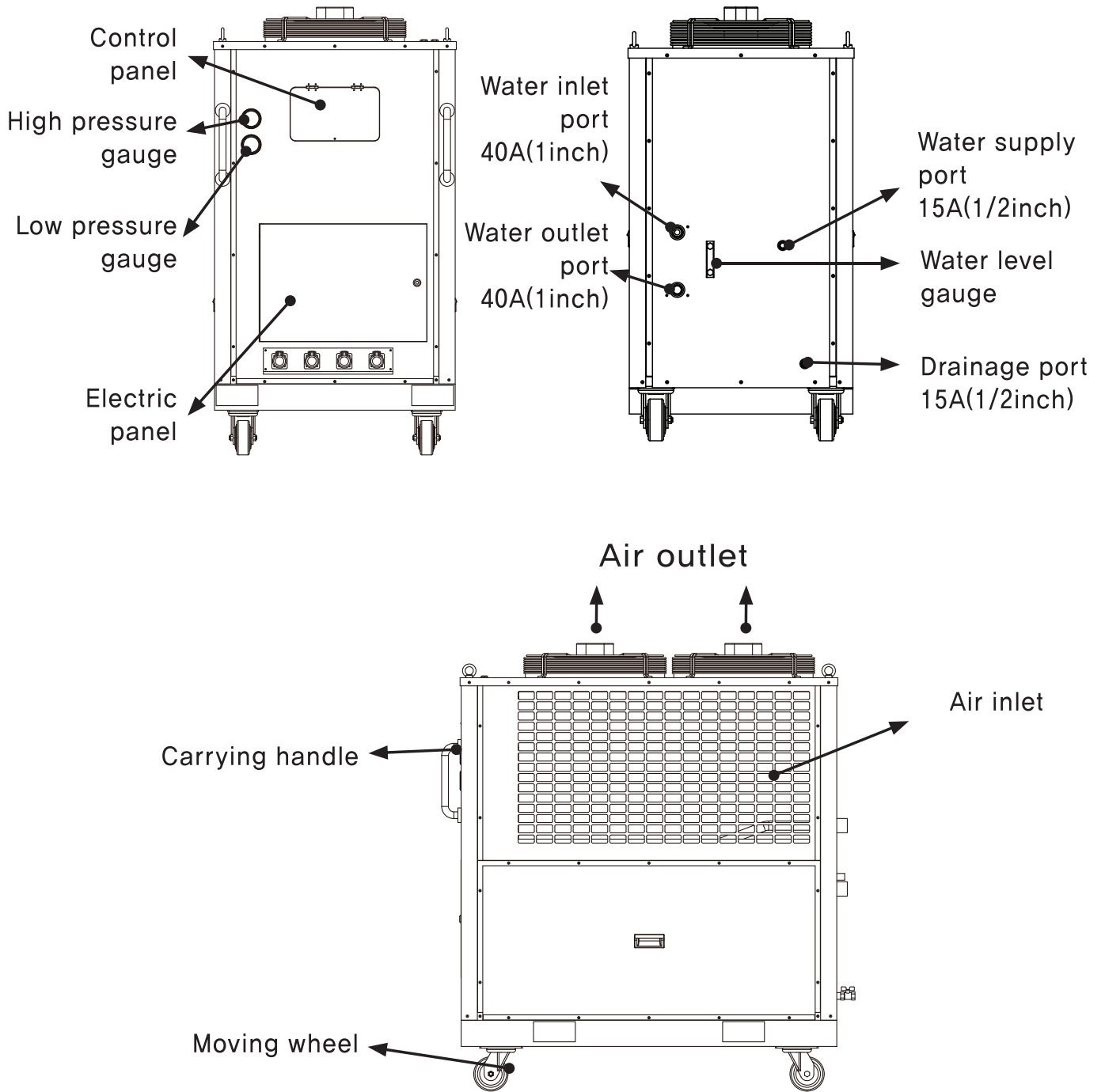

CAUTION WHILE MANEUVERING

1. While maneuvering, do not tilt the unit more than 40°. Too much tilting might cause malfunction of the machine. Do not put too much vibration or shock to prevent the gas leakage. To maneuver with forklift or hoist, please refer the below picture.

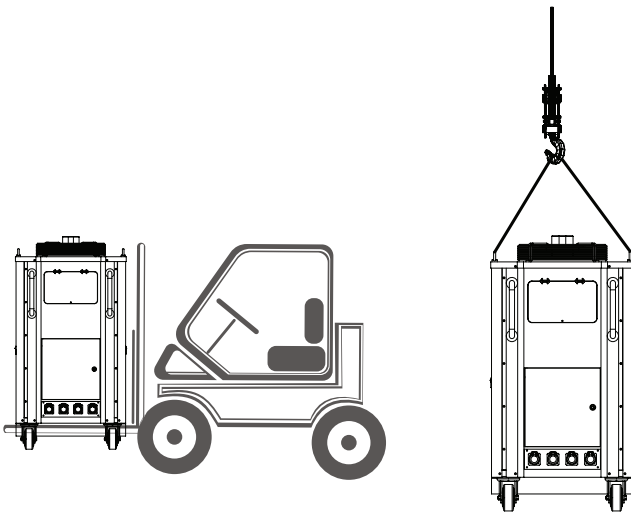

2. While using forklift
 - Make sure the machine is balanced well.
 - Make sure the fork is inserted deep enough to hold the machine stably.
3. While using hoist
 - Have the brackets on the top stay up to use hoist.
 - Use the hoist can stand more than 500 KG.
 - Make sure the machine is not tilted while using hoist.

INSTRUCTION FOR INSTALLATION

CHOOSING THE RIGHT SPOT TO INSTALL

1. Do not use the machine at where explosive, flammable gas leakage might happen.
2. Install the machine at where is well ventilated and has low humidity.
3. Do not place any external substance near the ventilation port.
4. Make sure the air inlet & outlet port have enough space to suck in & pull out the air.
5. Do not install the machine at powdery, dusty, oily area.

(Do not place any external substance within 500mm from the ventilation port)

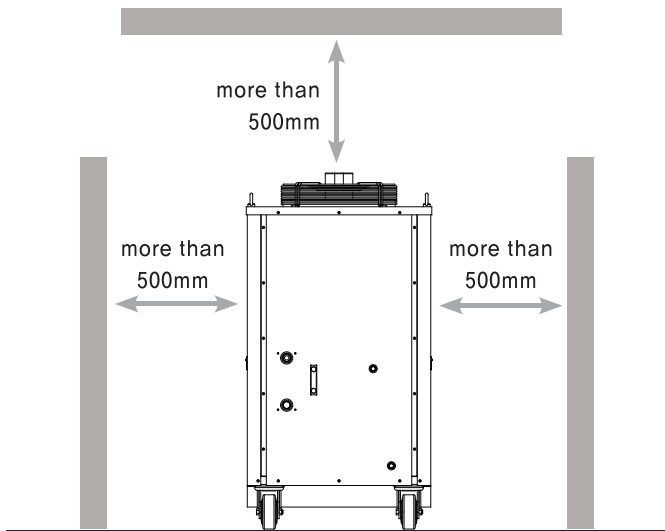

INSTRUCTION FOR THE VALVE CONNECTION

1. Make sure the pressure of the inlet valve lower than 0.1 Mpa, outlet valve lower than 0.6 Mpa.
2. Check if there is no leakage on the pipe while running.
3. Check the loose of the valve connection, leakage, infiltration of air while running.
4. While installing the pipe, avoid maneuver the valve to prevent losing the pressure.
5. Let the supply valve always open, as the machine is designed for auto-water supply system.
6. Make sure to connect the right valve of inlet & outlet port.
7. When the inner contamination is found for long-time using, drain out the water and refill it.
8. When not using for a long time, drain out the remaining water inside the machine using drainage valve and place the machine avoiding hot and humid place.

CONTROLLER MANUAL

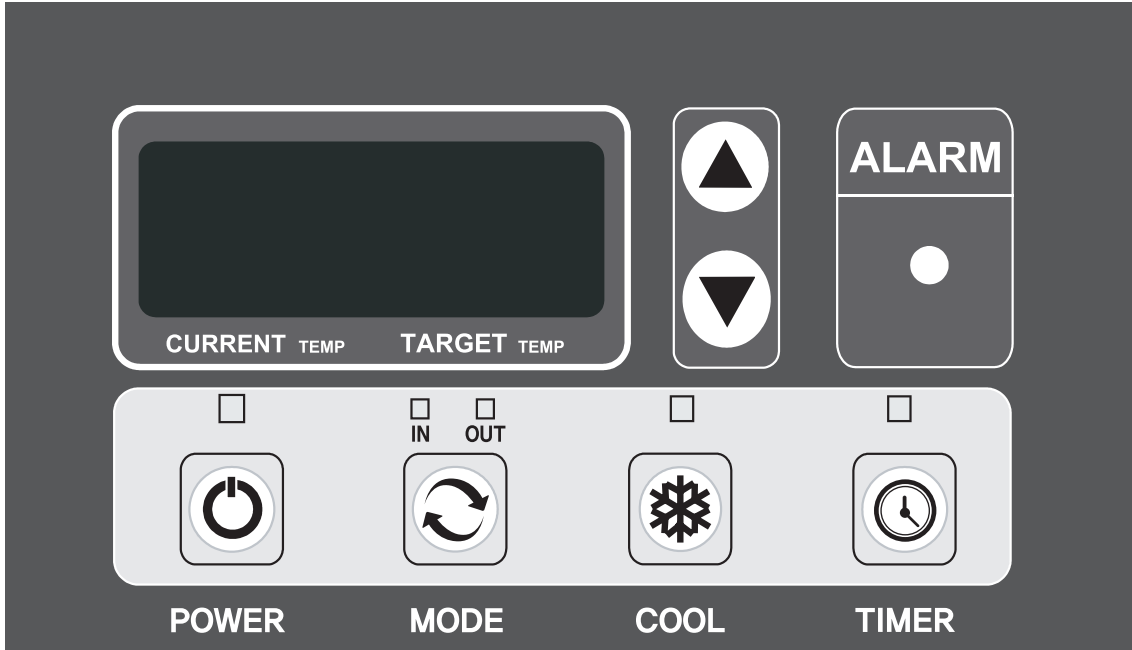

1. Power button

- Press and hold for 1 second to turn on the unit.
- Press and hold for 1 second to turn off the unit.



Note : When main power is on, compressor starts after 3 minutes.(Compressor protective system)
Power button LED : Showing the power is on / off.

2. Mode button

- Press the button to change the temperature sensor on inlet and outlet.
- When IN is on, the display shows inlet water temperature.
- When OUT is on, the display shows outlet water temperature.



Press the button to change the temperature sensor on inlet and outlet (IN ↔ OUT)
By pressing the button, you can set the target temperature. (5~30°C)

3. Cool button

- Press the button to select the cooling mode.
- When current temperature is higher than target temperature, the cooling starts. When current temperature is lower than target temperature, the cooling stops.



LED ON : Cooling on
LED OFF : Cooling off
(compressor stops, condenser fan stops, drainage pump starts)

4. Timer button

- Press the button to set the off-timer.
- The setting value is from 30 minutes to 12 hours.



LED ON : Off-timer on

LED OFF : Off-timer off



[hour] [minute]

After set the desired time, leave the unit not manipulate for 5 seconds to exit the setting mode OR press COOL button to exit immediately.

- Display shows [current temperature, target temperature] for 5 seconds and switch to [remain hour, minute] for 2 seconds.
 - When off-timer triggers to off the machine, the machine goes into stand-by mode.
5. Cancel the off-timer
- By turning off the machine pressing POWER button, the off-timer will be cancelled.
 - Enter the off-timer mode, set the value as '___', '___' to cancel the off-timer.
 - When the unit is shut down by external accident, the remaining time is memorized in the system when turning on again.

INSTRUCTION & CAUTION FOR RUNNING

1. Before initial start, fill up the tank with clean water (distilled water).
(subterranean water might cause blocking of the pipe and multiple malfunction)
2. Recommended water is distilled water and tap water.
 - Mixing ratio (prevent freezing until -2°C) distilled water : 90wt%, Antifreeze : 10~20wt%
(If the ratio is not correct, the circulation pump might have leakage.)
3. For the initial running, connect the valve and open it.
The water will be supplied automatically.
Check the water level gauge and run the machine.
4. Refer the picture below to check and supply the water.

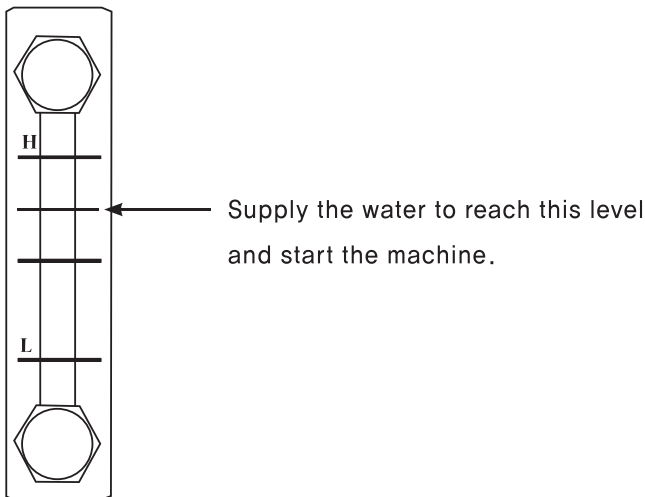

5. Never run the machine without the water.
This will damage the water pump.
6. Make sure the air not to go into the water pipe.
7. The compressor protective system will delay of the initial start of the compressor.
8. Do not put in fingers or tools through the ventilation port.
9. Do not put any kind of substance that has a chance to drop into the unit.
10. Do not place any kind of external substance near the ventilation port.
11. Make sure to not have your face near the air outlet to avoid any burnt from the heat.

MAINTENANCE

1. For the maintenance, cut off the power to the machine in advance.
2. Never do the maintenance while the machine is running.
This cause various accident.

CLEANING THE CONDENSER

Use the air gun or brush to clean the fin of the condenser.
Make sure not to bend or damage the fin.
Furthermore, do not use iron brush, it might damage the fin.













WATER TANK

1. Make sure to manage the water to be clean.
2. Clean the water inlet & outlet valve once every 6 months, to prevent any sludge block the pipe.
If the pipe or valve is blocked, it will make a loud noise and worsen the performance.
3. During the cold season, it is recommended to use anti freeze like ethylene glycol to prevent freezing to burst.

FOR LONG TIME STORAGE

1. Make sure to cut off the power.
2. Put the cover on the machine to prevent any external substance to infiltrate into the unit.
3. Make sure to manage the condensers not to have dust or oil mist on the surface.
4. Make sure to drain out all the water remaining inside the machine.

SELF-DIAGNOSTIC CODE

Alarm Display	Problem	Cause	Solutions
	Reversed phased	<ul style="list-style-type: none"> Power cable is connected wrongly 	<ul style="list-style-type: none"> Reconnect the power cable R,S,T correctly
	Compressor overload	<ul style="list-style-type: none"> Ambient temperature is too high Unstable power supply Compressor failure 	<ul style="list-style-type: none"> Do not run the machine when ambient temperature is higher than 45°C Reset the relay and check Contact the qualified service agency
	Water pump overcurrent	<ul style="list-style-type: none"> Pipe blocked Loosing pressure of the pipe Damage of the bearing of the motor or pump 	<ul style="list-style-type: none"> Inspect the blocking and clean it out Contact the service agency
	Fan motor over current	<ul style="list-style-type: none"> Unstable power supply Crack on the fan or Stuck Damage on the bearing 	<ul style="list-style-type: none"> Replace the fan motor Contact the service agency Reset the relay and check
	Water tank shortage	<ul style="list-style-type: none"> Loosing of flow in the circulation system Flow switch failure Water shortage of the evaporator Blocking of evaporator or condenser 	<ul style="list-style-type: none"> Inspect and fix the cause of the lost flow Supply the water to the tank Clean the evaporator and condenser
	High pressure	<ul style="list-style-type: none"> Too high ambient temperature Too high water temperature 	<ul style="list-style-type: none"> Do not run the machine when ambient temperature is higher than 45°C Contact the service agency Check the fan running
	Refrigerant low pressure switch	Refrigerant leakage or shortage	<ul style="list-style-type: none"> Replace low pressure switch Contact the service agency
	Too high inlet Water temperature	<ul style="list-style-type: none"> Not cooling properly Refrigerant shortage Water inlet temperature is higher than 45°C 	<ul style="list-style-type: none"> Contact the service agency
	Abnormal temperature sensor	cut out or connection failure of TH1(outlet) sensor	<ul style="list-style-type: none"> Contact the service agency
	Abnormal temperature sensor	cut out or connection failure of TH2(inlet) sensor	<ul style="list-style-type: none"> Contact the service agency
	Abnormal temperature sensor	cut out or connection failure of TH3(Anti freeze) sensor	<ul style="list-style-type: none"> Contact the service agency
	Anti freeze sensor activated	<ul style="list-style-type: none"> Too low temperature on evaporator or condenser Refrigerant shortage 	<ul style="list-style-type: none"> Operate under 5°C~ 45°C Contact the service agency

CIRCUIT DIAGRAM

WWC-1200

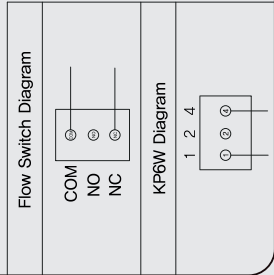
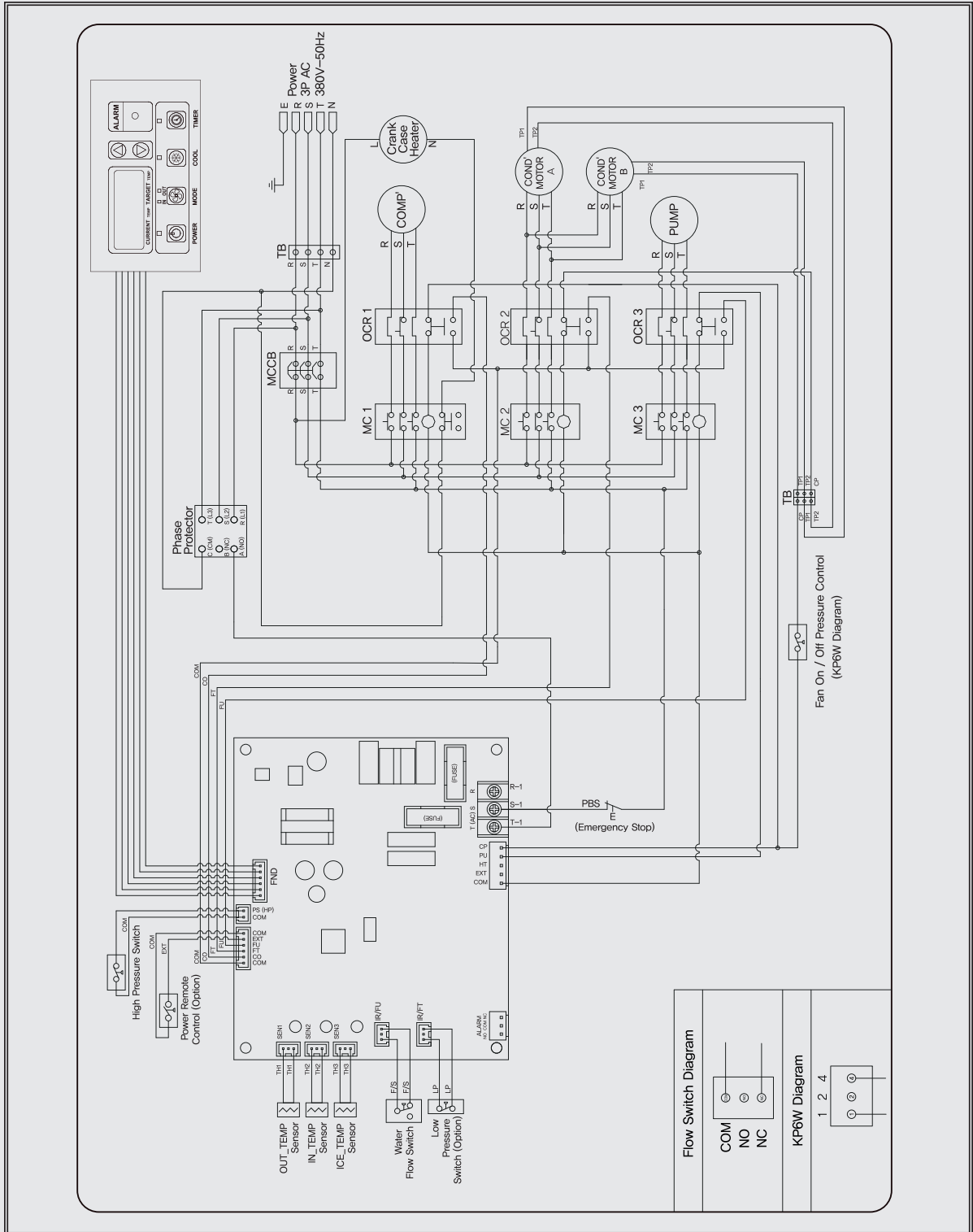

MODEL SPECIFICATION

Model	WWC-1200
Rated power	380V / 50Hz
Cooling capacity	131,706 BTU
Compressor	3phase scroll
Power consumption	14.9 Kw
Current consumption	22.58 Amps
Tank capacity(L)	120
Operation range (Ambient temperature) °F (°C)	50~113 (10~45)
Operation range (water inlet temperature) °F (°C)	41~86 (5~30)
Refrigerant type (kg)	R-410A (8)
Pump HP	3 HP
Design flow rate	72 gpm
Weight (kg)	392
Dimensions (mm)	900 x 1468 x 1658
Using fluid	distilled water, tap water(mix with 10% anti freeze)

- ❖ Tested under condition
 - Ambient temperature : 95°F(35°C) / 40%
 - Inlet water temperature : 53.6°F(12°C)